

CEMA Safety Labels Placement Guidelines

Product: Palletizers

Equipment: Hoist Area (PL-1)

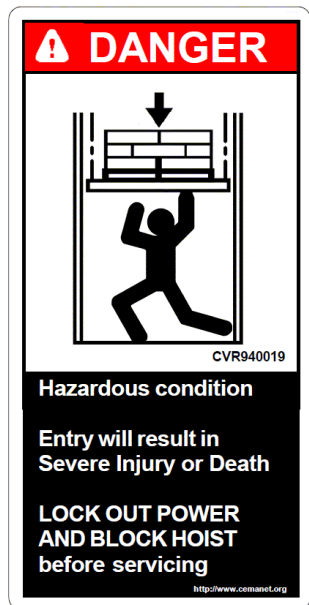
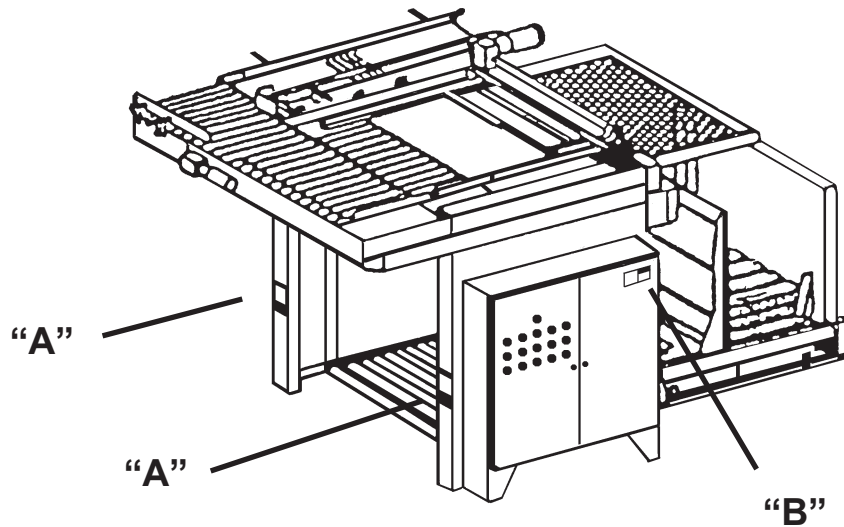

“A”

To be placed in clearly visible locations on both sides of any access area of palletizers to warn personnel of being crushed by the operation in the hoist area



“B”

To be placed at lockable disconnect switches which open control enclosures containing hazardous voltage wiring.