

CEMA Safety Labels Placement Guidelines

Product: Unit Handling Equipment

Equipment: Live Roller Conveyors - Belt Driven (UH-4)

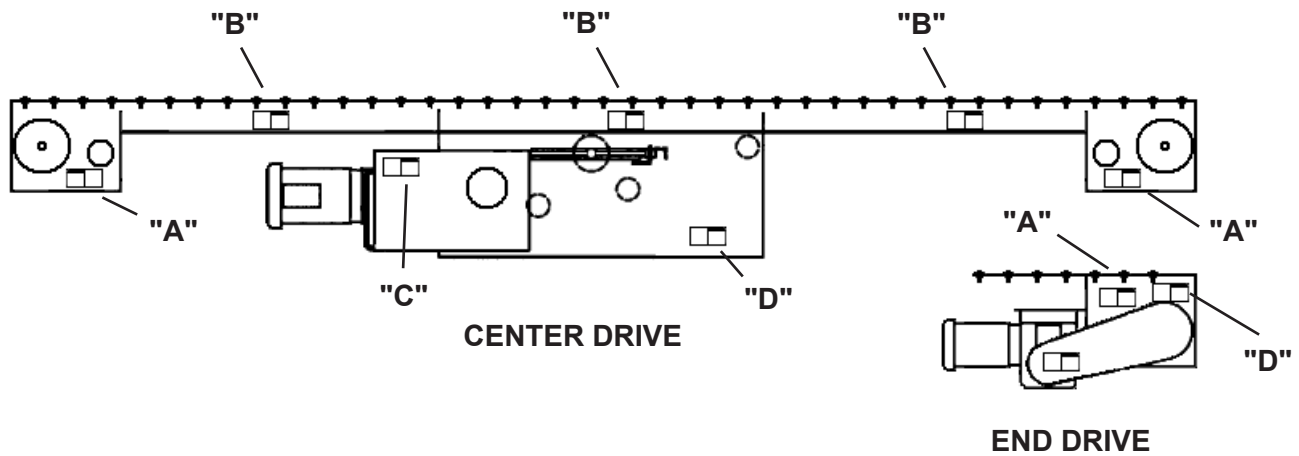

"A"

(LOCATE AT TERMINAL ENDS (BOTH SIDES))

To be located on conveyors where there are exposed moving parts which must be unguarded to facilitate function, i.e. rollers, pulleys, shafts, chains, etc.

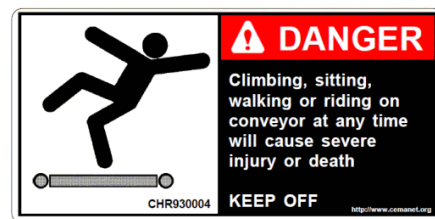

"B"

(SPACE UP TO A MAXIMUM OF 20 ft CENTERS (BOTH SIDES))

To be placed along both sides of these conveyors since these conveyors provide surfaces and profiles attractive, but hazardous, for climbing, sitting, walking, or riding.



"C"

(LOCATE ON DRIVE GUARDS AND CHAIN/BELT GUARDS)

To be placed on removable guards to warn that operation of the machinery with guards removed would expose chains, belts, gears, shafts, pulleys, couplings, etc. which create hazards

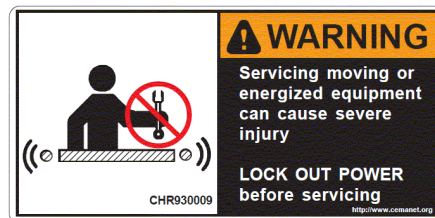

"D"

(LOCATE ON DRIVE SECTION (BOTH SIDES))

General purpose label to warn maintenance personnel that conveyors should be shut off and locked out prior to servicing. Examples: drives, takeups, lubrication points which require guard removal.