

# CEMA Safety Labels Placement Guidelines

Product: Bulk Handling Equipment

Equipment: Bulk Belt Conveyor Accessories (BH-2)



These labels are to be placed on or near the maintenance access for the following bulk belt conveyor accessories

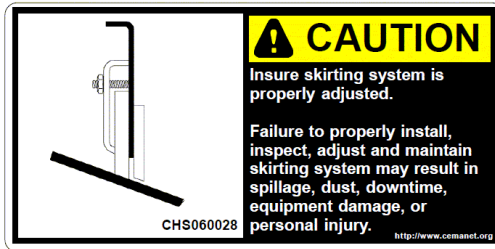

Belt Skirting Systems

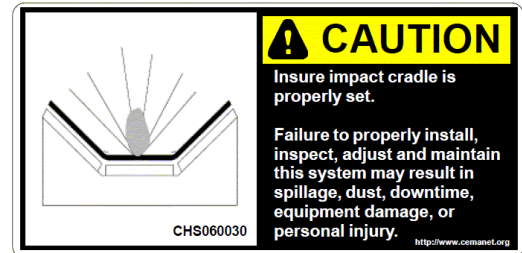

Impact Beds and Cradles

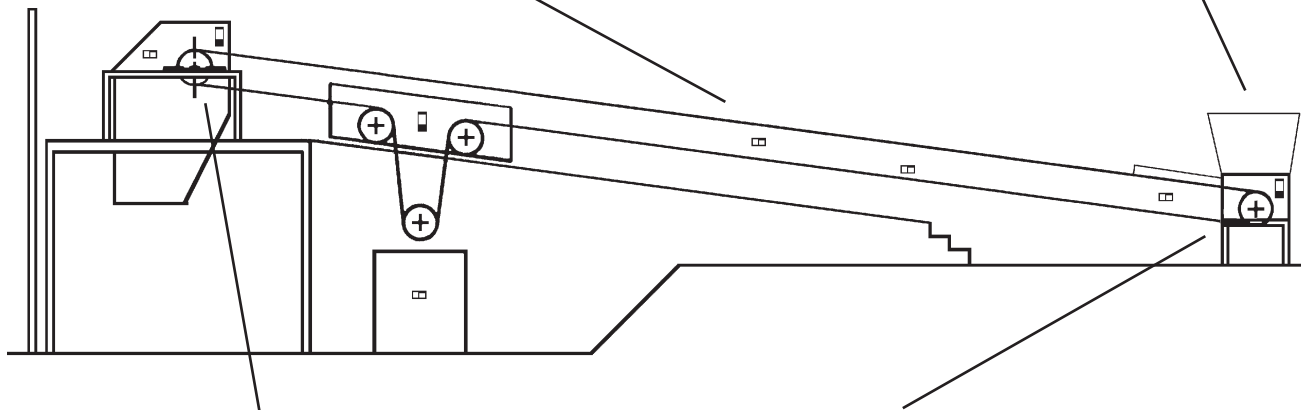

Belt Cleaners and Scrapers

Belt Tracking and Alignment Systems

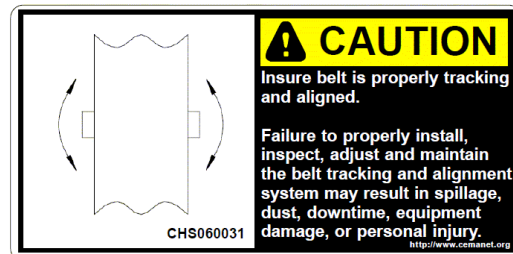
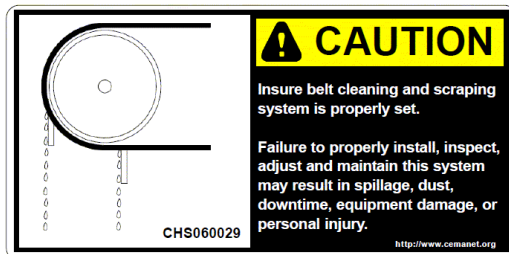

THIS GUIDELINE SUPPLEMENTS CEMA BULK HANDLING EQUIPMENT PLACEMENT GUIDELINE - BH-1